

# Knife Base Pullout Organizer

## Installation Instructions for KBPO-5SC/KBPO-8SC

Scan to watch the installation video  
<http://delivr.com/29x99>



### IMPORTANT:

Before you begin, make sure you familiarize yourself with all the parts and fully read the instructions.

### CUSTOMER SERVICE:

Toll-free customer help line available weekdays between 7:00am and 6:00pm Central Time at 800-463-0660.

### TOOLS NECESSARY:

Screw gun or Phillips screwdriver and tape measure. NOTE: If screw gun has a clutch, set to lowest setting so as not to over tighten and/or strip screws.

### PARTS IDENTIFICATION:

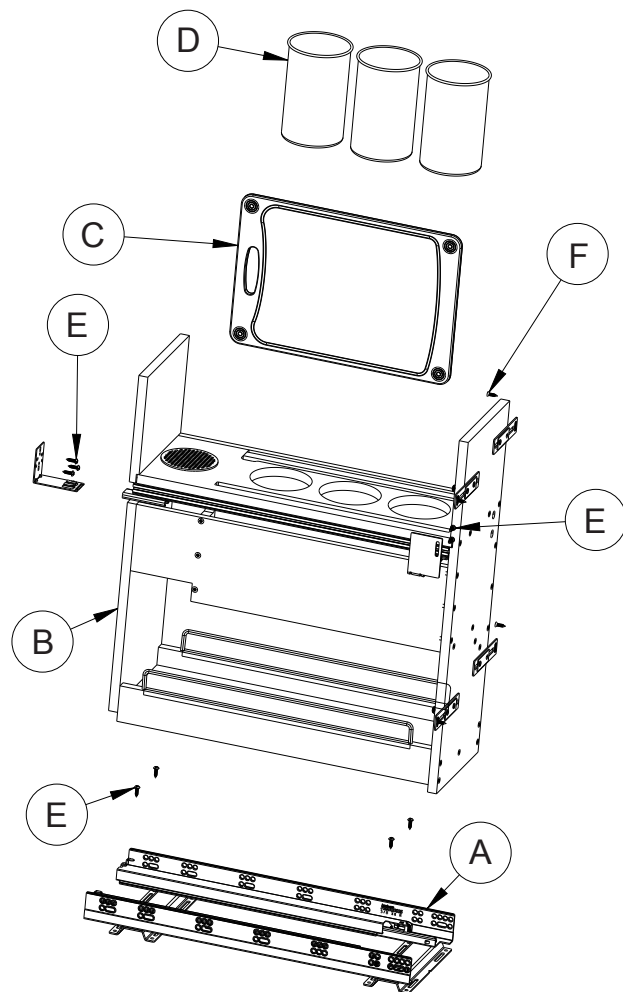

A	Mounting Base	1 pcs
B	Knife Base Pullout Organizer Unit	1 pcs
C	Cutting Board	1 pcs
D	Canisters (not standard in KBPO-5SC)	3 pcs
E	#8 x 5/8" Pan Head Phillips Wood Screw	9 pcs
F	#8 x 5/8" Flat Head Phillips Wood Screw	4 pcs

### STEP 1 - Prepare Organizer for Install

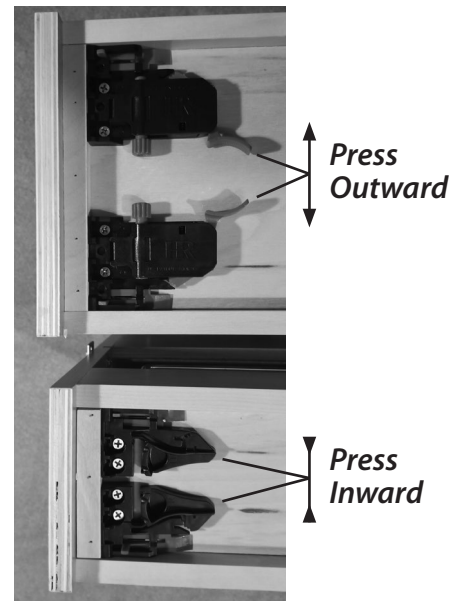

Remove the organizer from the slides by pressing the release clip as shown above.

### STEP 2 - Slide Base Installation

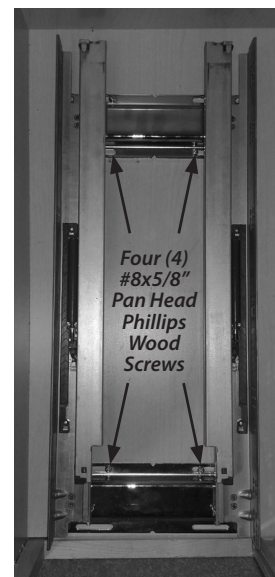

Place the slide base inside the cabinet, pulling the front cross member tight against the rear of the face frame. For frameless cabinets, set the front cross member back 3/4". For inset door applications, slide the base back from the above measurements plus the thickness of the door. Firmly secure with four (4) # 8 X 5/8" Pan Head Phillips Wood screws provided in the locations shown above. Replace the organizer onto the slide base. Proceed to the next step.

### STEP 3 - Mark Rear Mounting Bracket

1. Peel off the cover of the double sided tape.

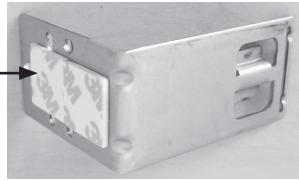

2. Apply inward force

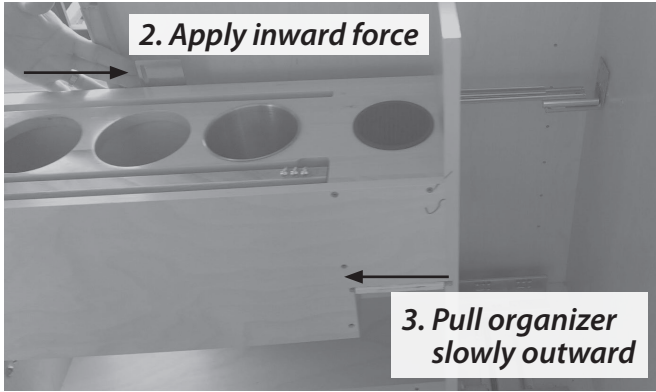

3. Pull organizer slowly outward

### STEP 4 - Install Rear Mounting Bracket

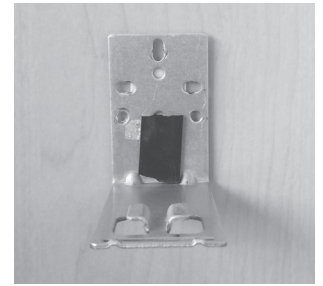

First, peel off the cover of the double sided tape at the back of the rear L-Bracket. Then applying an inward force at the front L-Bracket to ensure the rear L-Bracket has a firm contact with the cabinet back panel. While holding at the front L-Bracket, slowly pull the organizer halfway to gain access to the release clip to release the organizer from the slide base.

After remove the organizer from the slide base, the rear L-Bracket is firmly attached to the back panel. Use three (3) #8 x 5/8" Pan Head Wood Screws to secure the rear L-Bracket to cabinet's back panel. Then, replace the organizer back onto the slide base, and ensure the top slide mechanism engages with the rear L-Bracket. Operate the unit to make sure the undermount slides are working properly.

### STEP 5 - Install Front Mounting Bracket



Pull and adjust the front L-Bracket into position onto the side of the face frame (or cabinet). Allowing for a 3/16" setback. Firmly secure with two (2) #8 x 5/8" Pan Head Wood Screws. Make sure the gap between the unit and the side of the face frame is equal from top to bottom. Adjust accordingly and then securely tighten the bracket set screw (shown with a screw driver). Operate the unit and make adjustments as necessary for the slides to operate smoothly.

### STEP 6 - Door Installation

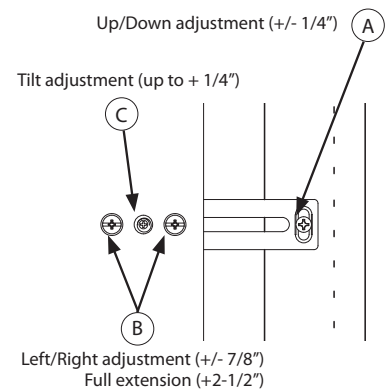

Using a tape measure, determine the mounting location of the top door mounting brackets. Install door with two (2) #8 X 5/8" Flat Head Phillips Wood Screws and make necessary adjustments following the diagram above. To adjust door up or down loosen door mounting screws (A). To adjust left or right, loosen both set screws (B) adjust and retighten. To adjust tilt, loosen tilt screw (C), adjust and retighten set screws. Once the door is in the desired position firmly secure the two bottom door mounting screws.

### STEP 7 - Finishing Touches

Unwrap the plastic cutting board and place it into the slot. If the unit came with canisters, Remove the canisters from its box and place them into their corresponding circular cutouts.